

Operations Manual



PDT-NSU-0005-MP-I

Revision 1.0 – August 2022



Parallax Digital Technologies Ltd
Unit 19 Endeavour Park, Baker Road
Nelson Park West, Cramlington
Northumberland, NE23 1XA



+44 (0)1670 202001



sales@parallaxdigital.co.uk

www.parallaxdigital.co.uk

Table of Contents

1.	Revision History	2
2.	Abbreviations.....	3
3.	Safety Information.....	4
3.1	General Safety Information	4
3.2	DC Power Supply	4
4.	Packing List	4
5.	Product Overview	5
6.	Connectors and Indicators.....	6
6.1	LED Indicators	6
6.2	RJ45 Ports	6
6.3	Power Supply Connector	7
6.4	PoE Compatibility	7
6.5	PoE Power Budget	7
7.	Installation Procedures.....	8
7.1	DIN Rail Installation	8
7.2	Wall Mount Installation.....	8
8.	Connection and Setup	9
8.1	Inspection Checks	9
8.2	RJ45 Connections.....	9
8.3	Power Up	9
9.	Physical Dimensions	9
10.	Hardware Specification	10

2. Abbreviations

Abbreviation	Description
AP	Access Point
CCA	Copper Clad Aluminium
DC	Direct Current
IEEE	Institute of Electrical and Electronic Engineers
IP	Internet Protocol
MTBF	Mean Time Between Failures
PD	Power Device
PoE	Power over Ethernet
PSU	Power Supply Unit

3. Safety Information

3.1 General Safety Information

WARNING

Only trained and authorised personnel should be permitted to work on this equipment. It is assumed that those using this guide are competent to work on equipment of this nature and will take appropriate precautions when working with the fault analysis guide.

All devices should be inspected upon receipt for signs of physical damage, which may in turn, affect operational performance, or the overall safety of the unit. Any damaged items should be returned to Parallax Digital Technologies Ltd for safety checks.

Parallax Digital Technologies accepts no responsibility for any injury or loss caused by unsafe or inadequate working practices, or for work carried out by an unauthorised third party.

To prevent possible danger, damage, and bodily harm when handling the equipment, please observe all warnings, cautions notices contained in this section. Failure to heed the following danger, warnings, and cautionary statements could lead to serious injury or death.

3.2 DC Power Supply

WARNING

The Unit should be mains-fed using a DC Power Supply using an appropriately rated cable assembly, which is protected internally at the power supply device itself. If the device is to be fed from an alternative power source, then the appropriate circuit protection device should be used to ensure that the supply circuit is interrupted, in the event that a fault in the device causes too much current to flow into it, causing an unsafe condition.

4. Packing List

The following items are included in the shipping carton:

- 1 x PDT-NSU-0005-MP-I Unmanaged Ethernet Switch
- 1 x DIN Rail Mounting Kit (Fitted)
- 1 x Wall Mounting Kit
- Operation & Maintenance Manual (May be electronically supplied)
- Declaration of Conformity (May be electronically supplied)

5. Product Overview

The PDT-NSU-0005-MP-I is an Unmanaged Ethernet PoE+ switch, providing 4 x 10/100 PoE+ RJ45 ports and 1 x 10/100 RJ45 port for connectivity, designed to directly connect to devices such as IP Cameras, Wireless APs, IP Telephones etc.

This model has a wide operating voltage range (+12-48VDC) making it suitable for a wide range of applications, including solar and battery powered, and it incorporates a voltage booster to ensure that the voltage outputs on the PoE ports are at a steady +48VDC to ensure compatibility with IEEE802.3af and IEEE 802.3at Standards.

The device is designed for use in harsh industrial environments, and incorporating a rugged aluminium housing, it can be operated across a wide temperature range (-40°C to +80°C) making it suitable for most conditions.

A typical application setup can be seen in the following diagram:

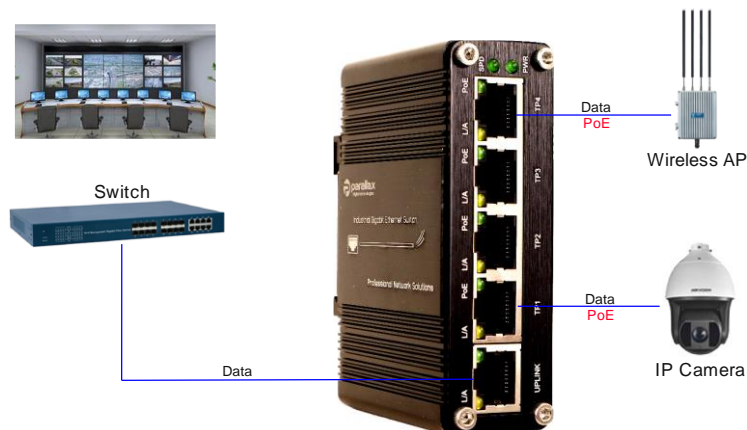

6. Connectors and Indicators

Front Panel



6.1 LED Indicators

The Front Panel LEDs display the status of the switch and the associated port connections as indicated in the table below:

LED	Name	Colour	State	Status
PWR	Power	Green	OFF	Unit Power Off
			ON	Unit Power On
L/A	Link Activity	Yellow	OFF	No Connection
			ON – Steady	Connection
			ON – Flashing	Data Tx/Rx
SPD	Uplink Speed	Green	OFF	100 Mbps
			ON – Steady	1000 Mbps
PoE	Power over Ethernet	Green	OFF	No PoE
			ON – Steady	PoE Established
			ON – Flashing	PD Detected

6.2 RJ45 Ports

The Front Panel has 5 RJ45 Ports and the Uplink Port is to be used to connect to the host network or device and is not PoE compatible. The remaining 4 ports are all PoE+ compatible and should be used as access ports.

6.3 Power Supply Connector

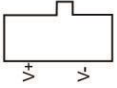
Model No	V-	V+	Power Input
PDT-NSU-0005-MP-I	GND	+12-48VDC	

Note: All Power Supplies should provide over-current and short-circuit protection, and should have a capacity rating to meet the required output current for the device plus any PoE powered device requirements

6.4 PoE Compatibility

Model No	IEEE 802.3af	IEEE 802.3at	IEEE 802.3bt
PDT-NSU-0005-MP-I	●	●	

The PoE output for this model is compatible with PoE and PoE+ Standards, as can be seen in the table above.

6.5 PoE Power Budget

Supply Voltage	+12VDC	+24VDC	+48VDC
Total PoE Budget	60W	90W	120W

The PoE Power Budget is dependent upon the input supply voltage, as shown in the above table.

7. Installation Procedures

7.1 DIN Rail Installation

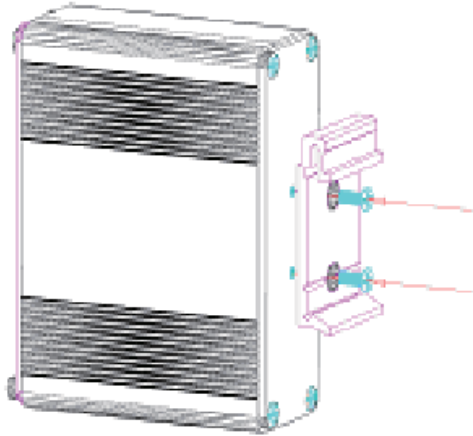

Attach the DIN Rail Bracket (if not fitted) to the switch case using the screws supplied

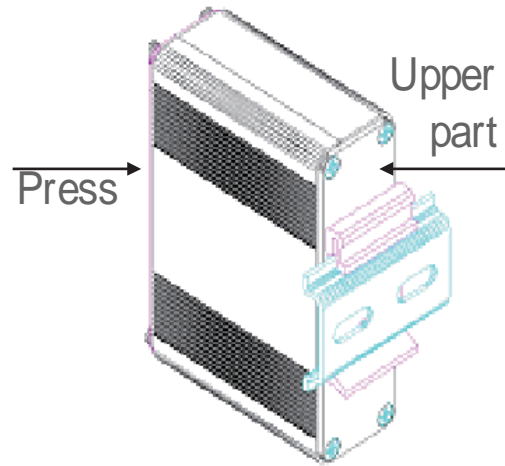

Clip the upper edge of the bracket onto the DIN Rail and push to latch the bottom strip

7.2 Wall Mount Installation

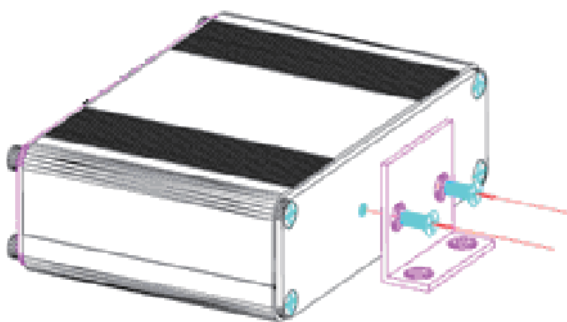

Attach the Wall Mount Bracket (if not fitted) to the switch case using the screws supplied

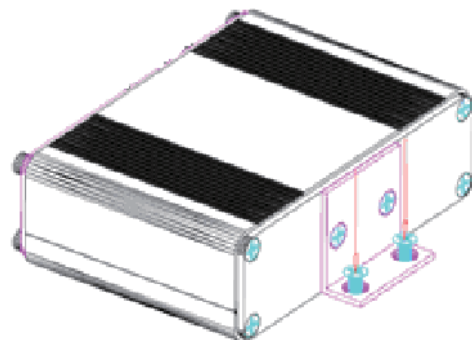

Mount the switch to the required surface using appropriate fixings

8. Connection and Setup

8.1 Inspection Checks

Please inspect the unit to ensure that there is no damage to the external casing which could cause a malfunction of the device or cause a safety critical fault. Any damaged units should be returned to Parallax Digital Technologies for inspection and testing.

Please ensure that the DC Cables are securely fastened in the terminal block, and that the terminal block is correctly inserted into the switch power connector housing.

8.2 RJ45 Connections

Ensure all required RJ45 Ports are connected correctly using CAT5e cable or better to the client devices. The Uplink port should be connected to the host device or network, and the access ports TP1-4 are available for other devices or connections. All cables should be solid copper and not CCA.

8.3 Power Up

The Unit will automatically power up as soon as DC power is applied to the device. The Power Light will be illuminated and after approximately 1 second, all of the other LEDs will flash on and off to complete the initialization sequence. Following this, the Port Status LEDs will display the current state of each of the ports.

9. Physical Dimensions



All Dimensions are in mm

10. Hardware Specification

ETHERNET

Standards

IEEE 802.3 Ethernet
 IEEE 802.3u Fast Ethernet
 IEEE 802.3x Full Duplex Flow Control
 IEEE 802.3az Energy Efficient Ethernet
 IEEE 802.3af Power over Ethernet
 IEEE 802.3at Power over Ethernet Plus

Forwarding and Filtering Rate

14,880pps (10Mbps)
 148,800pps (100Mbps)

Packet Buffer

512Kbits

Packet Length

2046B

MAC Address Table

2K

Exchange Property

Backplane Bandwidth 1Gbps
 Packet Forwarding Rate 14.88Mbps

INTERFACE

Wired

4 x 10/100/1000 PoE+ RJ45
 1 x 10/100/1000 RJ45

PoE

Standard

IEEE 802.3af/ 802.3at
 RJ45

Port

Power Pin Assignment

4/5 (+) 7/8 (-)

PoE Budget

48VDC Supply – 120W
 24VDC Supply – 90W
 12VDC Supply – 60W

ENVIRONMENTAL

Operating Temperature

-40°C to +80°C

Storage Temperature

-40°C to +85°C

Relative Humidity

5% - 95% non-condensing

MTBF

200,000 hours

ELECTRICAL

Operating Voltage

+12-48VDC (Terminal Block Connector)

Power Consumption

6w Without PoE Load

Short-Circuit Protection

Auto-Reset

Reverse Polarity

Protected

MECHANICAL

Dimensions

95mm x 70mm x 29mm

Weight

250g

Casing

Aluminium

Mounting

DIN Rail & Wall Mount

INDICATORS

PWR

Power

LNK

Link/Activity

SPD

Data Transmission Speed

CERTIFICATION

Electrical Safety	EN 62368-1:2020+A11:2020
Emissions	EN 55032:2015+A1:2020
Radiated Immunity	EN 55035:2017+A1:2020
Harmonic Emissions	EN 61000-3-2:2014
Fluctuations and Flicker	EN 61000-3-3:2013
Electro-Static Discharge	EN 61000-4-2:2009
Electromagnetic Field Immunity	EN 61000-4-3:2010
Electrical Fast-Transients	EN 61000-4-4:2012
Surge	EN 61000-4-5:2014+A1:2017
Conducted Immunity	EN 61000-4-6:2014
Power Frequency Magnetic Field	EN 61000-4-8:2010
RoHS	IEC 63000:2018

For all technical enquiries regarding this product, please contact our technical support team using the following email address:

support@parallaxdigital.co.uk