

- 1.25Gbps/1.063Gbps Operation
- 1310nm FP laser and 1550nm PIN Photodetector
- Supports Links up to 20km over SMF
- Compliant with SFP MSA and SFF-8472 with duplex LC Connector
- Compatible with CONET OC-24-LR-1
- Digital Diagnostics Monitoring for Internal or External Calibration
- Access to physical layer via 2-wire serial data bus
- +3.3V Single Power Requirement
- 0°C ~ +70°C Case Operating Temperature

Overview:

The PDT-SFP-02-1G-1310U-2000 is a low-cost, high-performance Small Form Pluggable (SFP) transceiver which is specifically designed for fiber communications with up to 1.25Gbps data rate, using SMF, over a distance of up to 20km. The transceiver consists of an FP transmitter, a PIN photodiode, integrated with a trans-impedance pre-amplifier, and an MCU control unit. The device transmits at 1310nm wavelength and receives at 1550nm wavelength. Access to internal Digital Diagnostic Memory Maps is possible using a 2-wire serial interface at addresses A0h and A2h. This is the commercial variant of this product and a wider temperature range variant is also available as part of the Industrial SFP Product Line. This product is compatible with Cisco and Parallax Digital Technologies products, as well as many other leading manufacturers, and pairs with PDT-SFP-02-1G-1310D-2000.

Mechanical Data

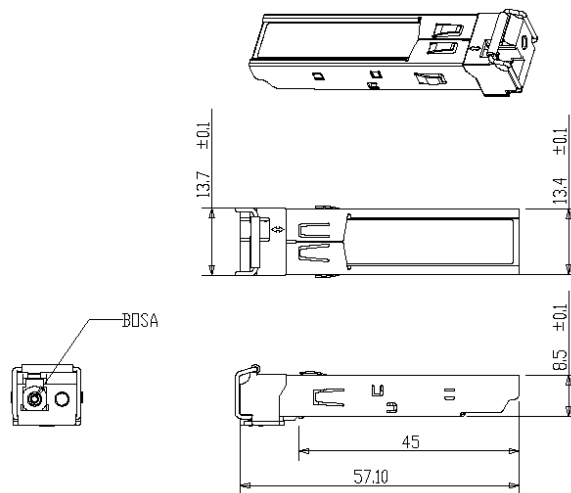

Ordering Information

Model	Description	Part No
PDT-SFP-02-1G-1310U-2000	1.25Gbps SFP Transceiver 1310nm Tx/1550nm Rx - LC 20km 0~70°C	0020-00005

Specifications And Availability Are Subject To Change Without Notice. Trademarks Are The Property Of Their Respective Owners.
Copyright © 2024 Parallax Digital Technologies Ltd. All Rights Reserved.

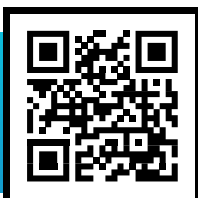

Parallax Digital Technologies Ltd
Unit 19 Endeavour Park, Baker Road
Nelson Park West, Cramlington
Northumberland, NE23 1XA



+44 (0)1670 202001



sales@parallaxdigital.co.uk

www.parallaxdigital.co.uk

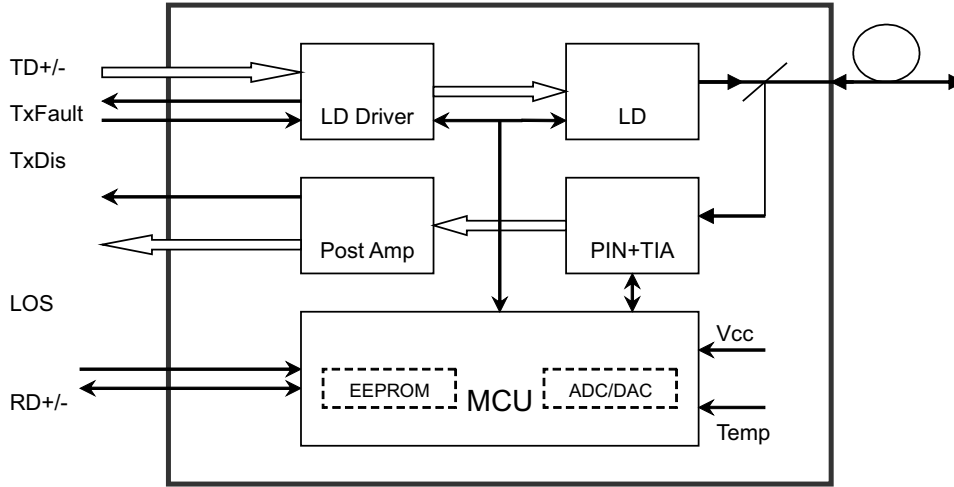

Module Block Diagram

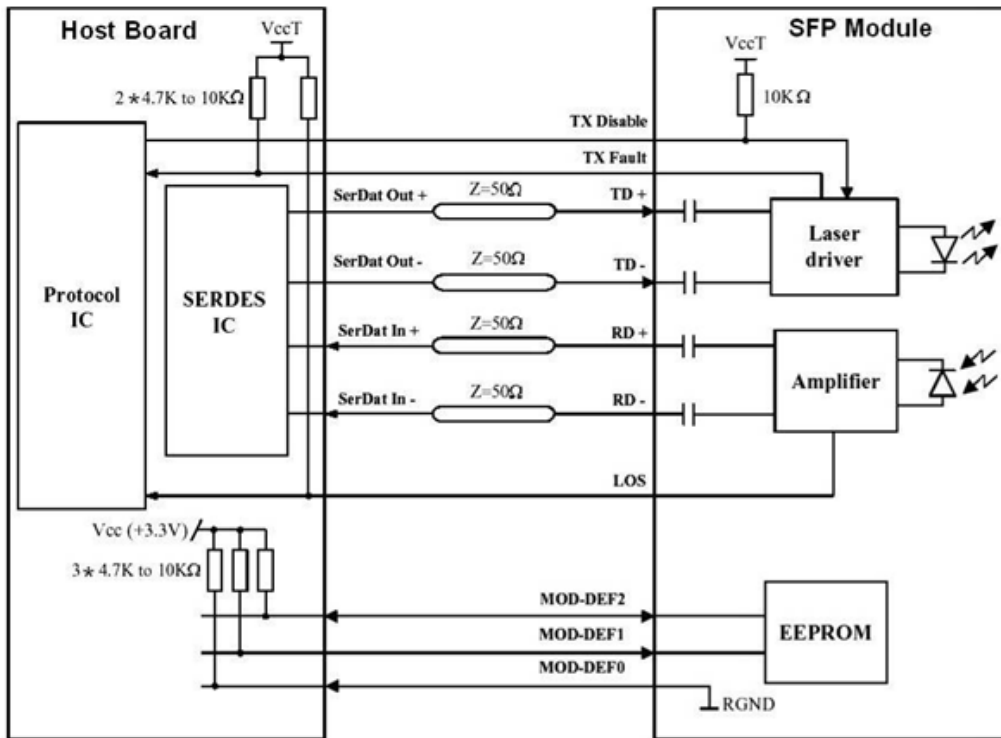

Module Block Diagram

Specifications And Availability Are Subject To Change Without Notice. Trademarks Are The Property Of Their Respective Owners.
Copyright © 2024 Parallax Digital Technologies Ltd. All Rights Reserved.



Technical Data

Pin	Signal Name	Description	Plug Seq.	Notes
1	V _{EET}	Transmitter Ground	1	
2	TX FAULT	Transmitter Fault Indication	3	Note 1
3	TX DISABLE	Transmitter Disable	3	Note 2
4	MOD_DEF(2)	SDA Serial Data Signal	3	Note 3
5	MOD_DEF(1)	SCL Serial Clock Signal	3	Note 3
6	MOD_DEF(0)	TTL Low	3	Note 3
7	Rate Select	Not Connected	3	
8	LOS	Loss of Signal	3	Note 4
9	V _{EER}	Receiver ground	1	
10	V _{EER}	Receiver ground	1	
11	V _{EER}	Receiver ground	1	
12	RD-	Inv. Received Data Out	3	Note 5
13	RD+	Received Data Out	3	Note 5
14	V _{EER}	Receiver ground	1	
15	V _{CCR}	Receiver Power Supply	2	
16	V _{CCT}	Transmitter Power Supply	2	
17	V _{EET}	Transmitter Ground	1	
18	TD+	Transmit Data In	3	Note 6
19	TD-	Inv. Transmit Data In	3	Note 6
20	V _{EET}	Transmitter Ground	1	

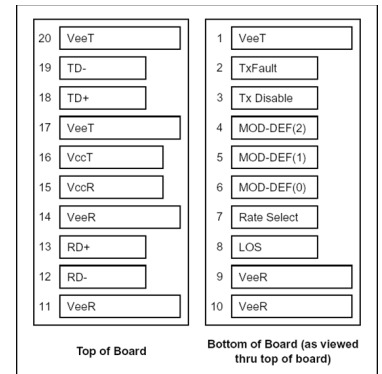

Pin Definitions

Notes:

Plug Sequence: Pin Engagement Sequence During Hot Plug

1 - TX Fault is an open collector output, which should be pulled up with a 4.7k~10kΩ resistor on the host board to a voltage between 2.0V and V_{cc}+0.3V.

Logic 0 indicates normal operation;
Logic 1 indicates a laser fault of some kind.
In the low state, the output will be pulled to less than 0.8V.

2 - TX Disable is an input that is used to shut down the transmitter optical output. It is pulled up within the module with a 4.7k~10kΩ resistor. Its states are:

Low (0 to 0.8V):	Transmitter on
(>0.8V, < 2.0V):	Undefined
High (2.0 to 3.465V):	Transmitter Disabled
Open:	Transmitter Disabled

3 - Mod-Def 0,1,2. These are the module definition pins. They should be pulled up with a 4.7k~10kΩ resistor on the host board.

The pull-up voltage shall be V_{ccT} or V_{ccR}.

Mod-Def 0 is grounded by the module to indicate that the module is present
Mod-Def 1 is the clock line of two wire serial interface for serial ID
Mod-Def 2 is the data line of two wire serial interface for serial ID

4 - LOS is an open collector output, which should be pulled up with a 4.7k~10kΩ resistor. Pull up voltage between 2.0V and V_{cc}+0.3V.

Logic 1 indicates loss of signal;
Logic 0 indicates normal operation.
In the low state, the output will be pulled to less than 0.8V.

5 - RD-/+ : These are the differential receiver outputs. They are internally AC-coupled 100 differential lines which should be terminated with 100Ω (differential) at the user SERDES.

6 - TD-/+ : These are the differential transmitter inputs. They are internally AC-coupled, differential lines with 100Ω differential termination inside the module.

Specifications And Availability Are Subject To Change Without Notice. Trademarks Are The Property Of Their Respective Owners.
Copyright © 2024 Parallax Digital Technologies Ltd. All Rights Reserved.



Parallax Digital Technologies Ltd
Unit 19 Endeavour Park, Baker Road
Nelson Park West, Cramlington
Northumberland, NE23 1XA



+44 (0)1670 202001



sales@parallaxdigital.co.uk

www.parallaxdigital.co.uk

Technical Data

Parameter	Range	Unit	Accuracy	Calibration
Temperature	0 to +70	°C	±3°C	Internal / External
Voltage	3.0 to 3.6	V	±3%	Internal / External
Bias Current	0 to 100	mA	±10%	Internal / External
TX Power	-9 to -3	dBm	±3dB	Internal / External
RX Power	-23 to 0	dBm	±3dB	Internal / External

Digital Diagnostics Parameters

The transceivers provide serial memory contents and diagnostic information about the current operating status of the device using the 2-wire serial interface (SCL/SDA), and the digital diagnostic memory map is as follows:

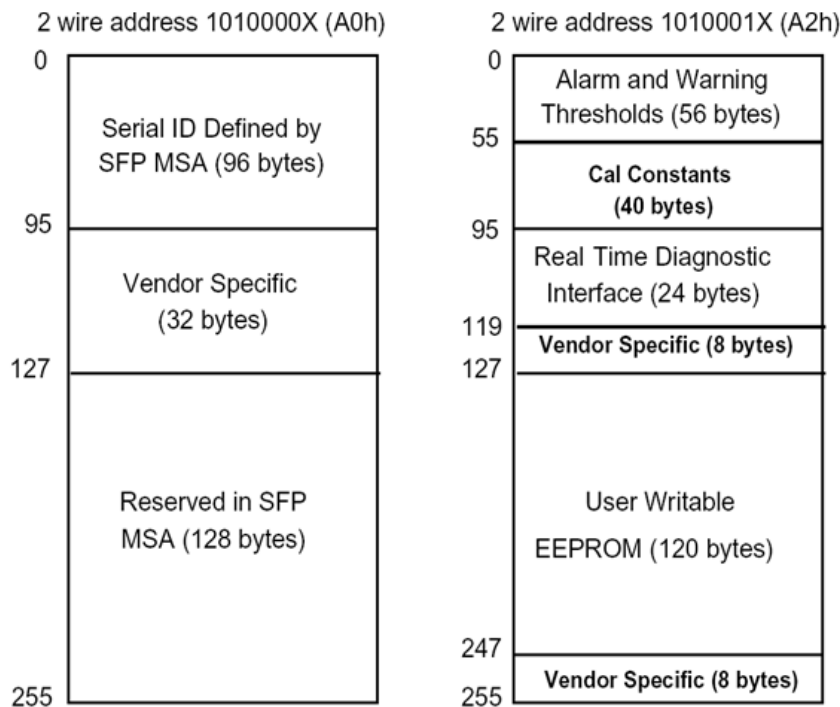

Specifications And Availability Are Subject To Change Without Notice. Trademarks Are The Property Of Their Respective Owners.
Copyright © 2024 Parallax Digital Technologies Ltd. All Rights Reserved.



Parameter	Symbol	Min	Typical	Max	Unit	Notes
Transmitter						
Centre Wavelength	λ_c	1260	1310	1360	nm	
Spectral Width (RMS)	σ			4	nm	
Average Output Power	Pout	-9		-3	dBm	1
Extinction Ratio	ER	9			dB	
Optical Rise/Fall Time (20%~80%)	t _r /t _f			0.26	ns	
Data Input Swing Differential	V _{IN}	400		1800	mV	2
Input Differential Impedance	Z _{IN}	90	100	110	Ω	
TX Disable	Disable		2.0		V _{cc}	V
	Enable		0		0.8	V
TX Fault	Fault		2.0		V _{cc}	V
	Normal		0		0.8	V
Receiver						
Centre Wavelength	λ_c	1480		1580	nm	
Receiver Sensitivity				-23	dBm	3
Receiver Overload		-3			dBm	3
LOS De-Assert	LOS _D			-24	dBm	
LOS Assert	LOS _A	-35			dBm	
LOS Hysteresis		1		4	dB	
Data Output Swing Differential	V _{out}	400		1800	mV	4
LOS	High	2.0			V _{cc}	V
	Low			0.8	V	V

Optical & Electrical Characteristics

Notes:

- 1 - The optical power is launched into MMF
- 2 - PECL input internally AC-Coupled and Terminated
- 3 - Measure with a PBRS 2⁷-1 test pattern @1250Mbps - BER $\leq 1 \times 10^{-12}$
- 4 - Internally AC-Coupled

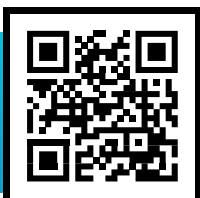

Technical Data

Parameter	Symbol	Min	Typical	Max	Unit
Tx Disable Negate Time	t_on			1	ms
Tx Disable Assert Time	t_off			10	µs
Time To Initialize , including Reset of Tx Fault	t_init			300	ms
Tx Fault Assert Time	t_fault			100	µs
Tx Disable To Reset	t_reset	10			µs
LOS Assert Time	t_loss_on			100	µs
LOS De-assert Time	t_loss_off			100	µs
Serial ID Clock Rate	f_serial_clock			400	KHz
MOD_DEF (0:2) -High	V _H	2		V _{cc}	V
MOD_DEF (0:2) -Low	V _L			0.8	V

Timing and Electrical Interface

Parameter	Symbol	Min	Max	Unit
Supply Voltage	V _{cc}	-0.5	4.5	V
Storage Temperature	T _s	-40	+85	°C
Operating Humidity	-	5	85	%

Absolute Maximum Ratings

Parameter	Symbol	Min	Typical	Max	Unit
Operating Case Temperature Commercial	T _c	0		+70	°C
Power Supply Voltage	V _{cc}	3.13	3.3	3.47	V
Power Supply Current	I _{cc}			300	mA
Data Rate	Gigabit Ethernet		1.25		Gbps
	Fiber Channel		1.063		

Recommended Operating Conditions

Specifications And Availability Are Subject To Change Without Notice. Trademarks Are The Property Of Their Respective Owners.
Copyright © 2024 Parallax Digital Technologies Ltd. All Rights Reserved.

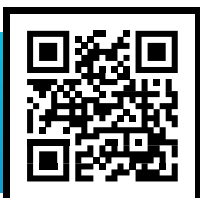

Parallax Digital Technologies Ltd
Unit 19 Endeavour Park, Baker Road
Nelson Park West, Cramlington
Northumberland, NE23 1XA



+44 (0)1670 202001



sales@parallaxdigital.co.uk

www.parallaxdigital.co.uk

Technical Data

Feature	Agency	Standard	Certificate / Comments
Laser Safety	FDA	CDRH 21 CFR 1040 and Laser Notice No. 50	1120289-000
Product Safety	BST	EN 60825-1: 2007 EN 60825-2: 2004 EN 60950-1: 2006	BT0905142009
Environmental protection	SGS	RoHS Directive 2002/95/EC	GZ0902008347/CHEM
EMC	WALTEK	EN 55022:2006+A1:2007 EN 55024:1998+A1+A2:2003 -	WT10093768-D-E-E

Compliance Data

Specifications And Availability Are Subject To Change Without Notice. Trademarks Are The Property Of Their Respective Owners.
Copyright © 2024 Parallax Digital Technologies Ltd. All Rights Reserved.



Parallax Digital Technologies Ltd
Unit 19 Endeavour Park, Baker Road
Nelson Park West, Cramlington
Northumberland, NE23 1XA



+44 (0)1670 202001



sales@parallaxdigital.co.uk

www.parallaxdigital.co.uk